

4 3 2 1

F

F

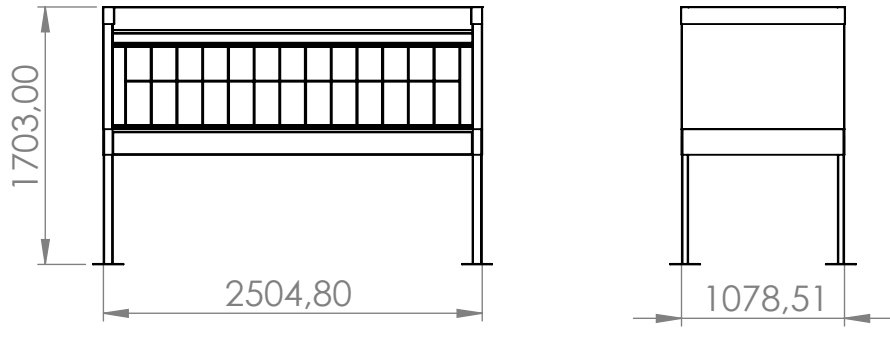

E

E

D

D

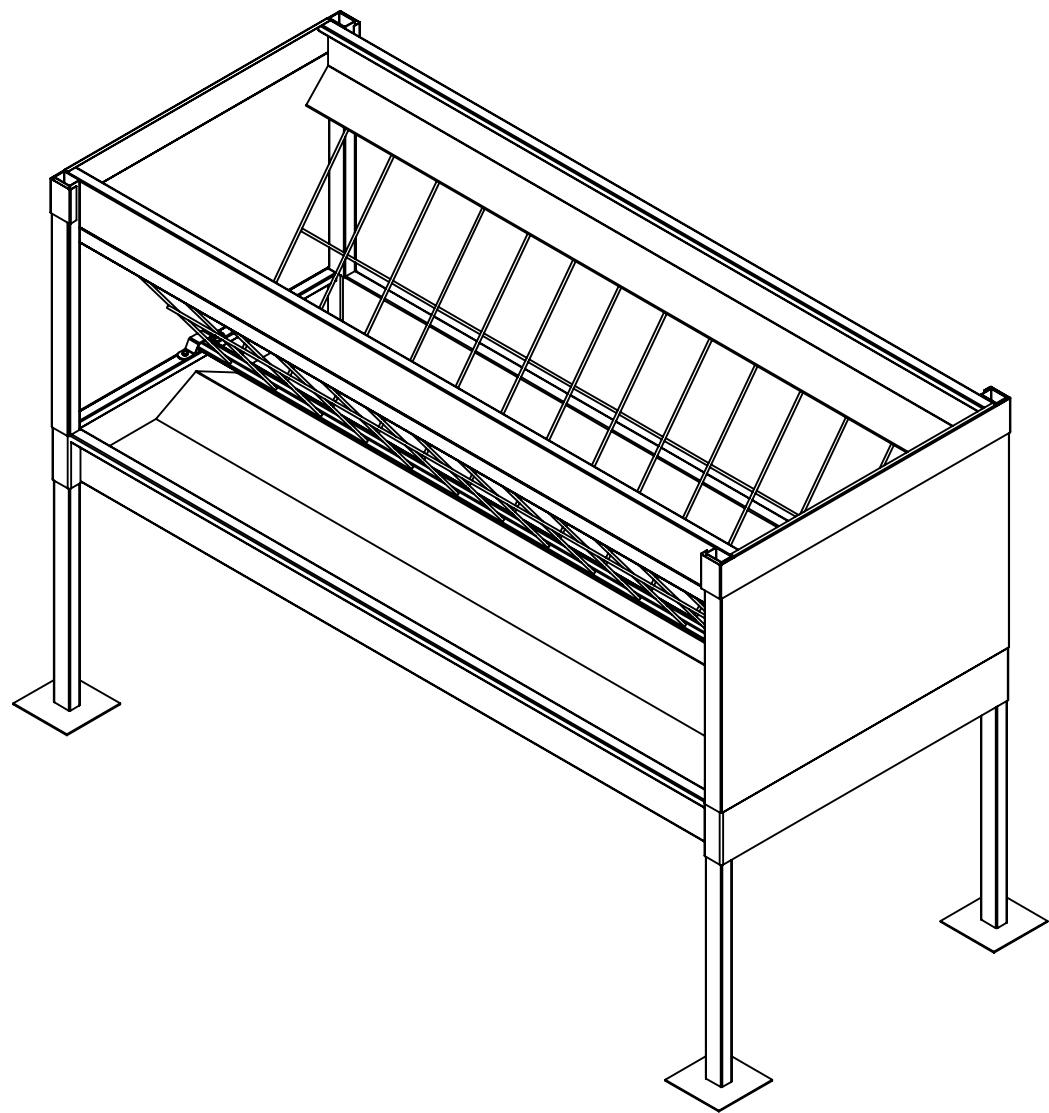

C

C

B

B



JAVIER CAMARA
INDUSTRIAS GANADERAS

PIEZA	NOMBRE	FECHA
PLANOS	JAVIER ARACIL	22/06/2021
		24/06/2021

A

A

ESPEJOR:	DESCRIPCIÓN:
MANO:	DIMENSIONES GENERALES (CH DESPLEGADA): mm
ESCALA: 1:50 HOJA 1 DE 1	FABRICADO: MATERIAL:

PRODUCTO: A005 - Comedero vacuno con rejilla
CÓDIGO: A005

4 3 2 1